

MODEL 380 OPTICAL PORTAL

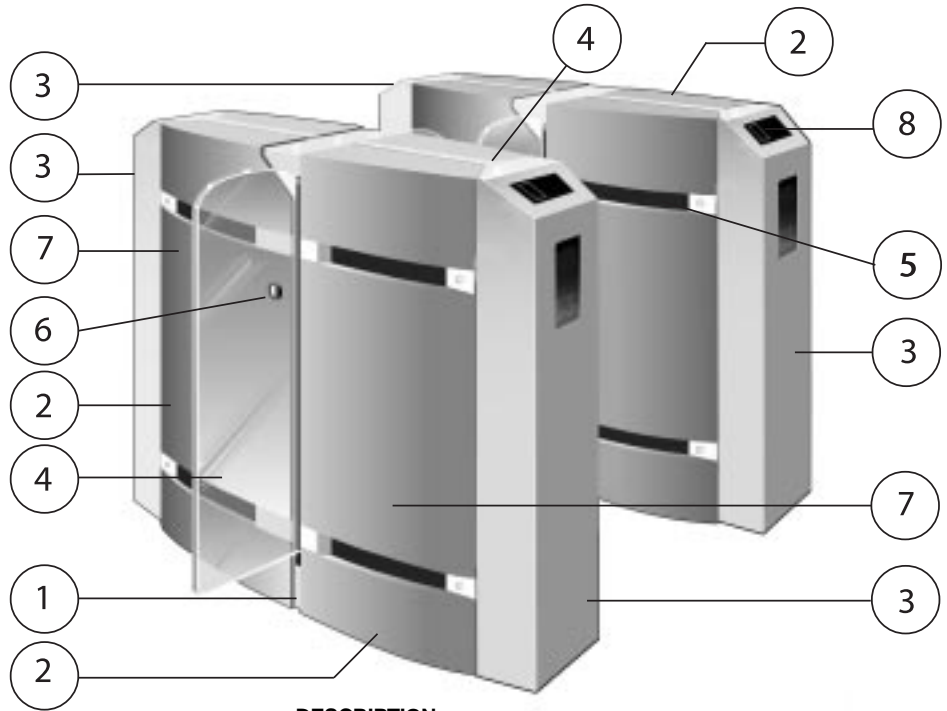

1. SELF SUPPORTING FRAME.
2. METALLIC OR COMPOSITE SIDE PANELS.
3. METALLIC END CAPS.
4. RETRACTABLE SECURITY PANELS, SAFETY GLASS.
5. ACTUATION AND TRACKING SENSORS.
6. SAFETY SENSORS.
7. HINGE MOUNTED SERVICE PANELS.
8. VISUAL CUEING DISPLAY



OPTICAL PORTALS:

The Model 380 Optical Portal is designed and manufactured by Automatic Systems. This unique patented pedestrian access portal installed in conjunction with any access control system provides a very high degree of entrance security. Designed to provide optimum pedestrian throughput, in an elegant, sophisticated and discreet manner, which is essential for today's corporate environment.

SECURITY:

The Model 380 utilizes retractable security panels, which are both safe and unobtrusive to the authorized user. However, by utilizing certain full height options, portals do provide an insurmountable obstacle to an UN-authorized user. Security concerns such as tailgating and jumping over the portals can be virtually eliminated. Both audio and visual alarms assist security personnel in monitoring access.

THROUGHPUT:

A programmable logic controller allows the Optical Portal to fully integrate with other systems. As a result, it operates in numerous modes, thereby facilitating the uninterrupted passage of large numbers of authorized people, which is especially important during peak hours. The expected throughput capacity is 45 people per minute, per lane.

SAFETY:

Many required safety features are provided, including the emergency opening of security panels in the event of a power failure, fire alarm, or other emergency situations. Another vital safety feature includes safety panel sensors, which prevent the retractable security panels from ever hitting users. In addition, both audio and visual indicators are used to assist both users and security personnel.

UL 325 Certified.

Specifications subject to change without prior notice

DESCRIPTION:

1. **Advanced design:** The design includes a highly rigid self-supporting frame; integrating the electromechanical assembly, which utilizes and advanced system of AC-motors with frequency drives, for each of the retractable security panels. Sensors include: actuation, blocking, tracking, and safety sensors. All of which are synchronized through the use of a Programmable Logic Controller.
2. **Maintenance and service:** Hinge-mounted key-locked cabinet panels can be opened to a 90° angle to allow easy access to both the electro-mechanical drive and to the electronic control units. In addition, general cleaning and maintenance are minimal. Advanced computer diagnostics is the cornerstone of the design.
3. **Physical Access Control:** Front and rear end caps are made of 14 gauge ANSI 304 stainless steel, #4 brushed finish. These end sections integrate visual cueing devices, as well as the users' access control devices (badge, biometrics, ticket reader, etc.) to provide safe and quick passage in one or both directions.
4. **Safety glass panels:** Thickness is a nominal 1/2". Glass security panels completely retract into the cabinet during each movement, utilizing specially designed safety finger guards. Optional materials and custom tinting are available.
5. **Photoelectric sensors:** Combination of actuating, blocking, tracking, and safety sensors ensuring users' a safe passage through the portal. Configurations include up to a total of 13 sensors

Specifications and dimensions on reverse side

MODEL380
OPTICAL PORTAL

TECHNICAL DATA
ACS-1001-EN

UL FILE #E210350
USA

MANUFACTURING FACILITY
CERTIFIED NBN EN ISO 9001



TECHNICAL CHARACTERISTICS:

- Electrical power supply: 115V single-phase.
- Frequency: 60Hz.
- Geared motor: 0.18kW AC ¼ HP with frequency drive.
- Power consumption:
 - Inactive = 100W per portal.
 - Operational = 600W per portal.
- Control logic: PLC
- Torque limiter: electronic.
- Driving mechanism: crankshaft-rod device for smooth operation with fast and progressive movements.
- Automatic opening device in case of power failure.
- Opening time: 1/2 second.
- Closing time: UL certified for safety.
- Anti-corrosion treatment (see specification)
- Operating temperature: -20°C to +50°C (-4°F to 122°F)
- Net weight:
 - Intermediate gate: 420 lbs.
 - Outer gate (left or right): 320 lbs.
- Overall dimensions: see below.

OPTIONS:

- Custom retractable security panels, materials or finishes.
- Sticker or sand-blasted logo on retractable panels.
- Custom heights for retractable panels, up to 67" (1700 mm)
- Fixed above cabinet security panels.
- Cabinet options: Cabinets are available in both the standard 100% metallic; or composite models, which are a combination of stainless steel and composite materials. A Variety of colors are available for composite units.
- Integration of customer proximity readers.
- Visual cueing displays built into the end of the entrance cabinet to assist both authorized and unauthorized users on the proper use of portal.
- Remote control panels and alarms.
- Handicap accessible ADA compliant options: Model 390 optical portal; or Model 335 optical gate.
- Custom tops (hand rails) available.
- **MODE OF OPERATIONS: (Entering and Exiting)**
 - Controlled (Card, Ticket, Biometrics, etc.)
 - Free passage
 - Locked

OVERALL DIMENSIONS:

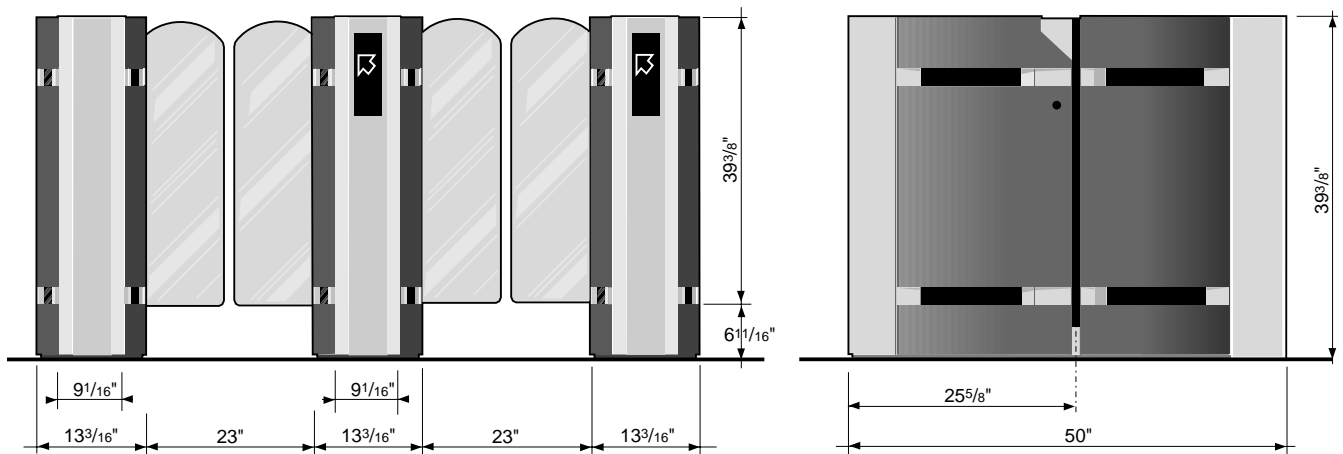

INSTALLATION PATTERN:

An access walkway has a left and a right gate, each consisting of a half obstacle panel and operating simultaneously.

To install a series of several access walkways, all that is needed is to place one or more intermediate units each with 2 half obstacle panels between them and operating simultaneously with the other half obstacle panel of the controlled access walkway (see below).

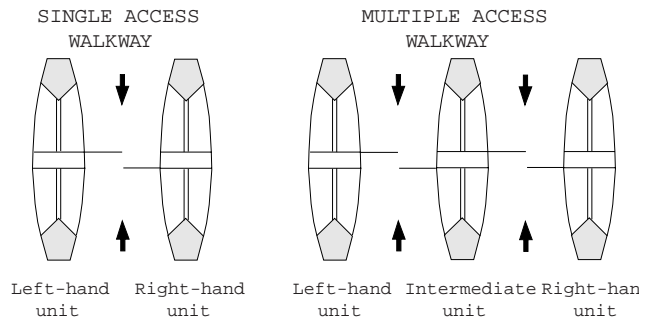

VISUAL CUEING PICTOGRAMS (OPTIONAL)



READY



WAIT



GO

ORIENTATION PICTOGRAMS (OPTIONAL)

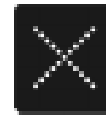

PASSAGE OUT OF SERVICE

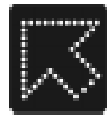

PASSAGE IN SERVICE

**MODEL380
OPTICAL PORTAL
TECHNICAL DATA
ACS-1001-EN**

**UL FILE #E210350
USA
MANUFACTURING FACILITY
CERTIFIED NBN EN ISO 9001**

